

Construction are made from glued wood, galvanized steel.

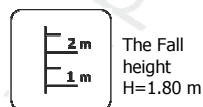
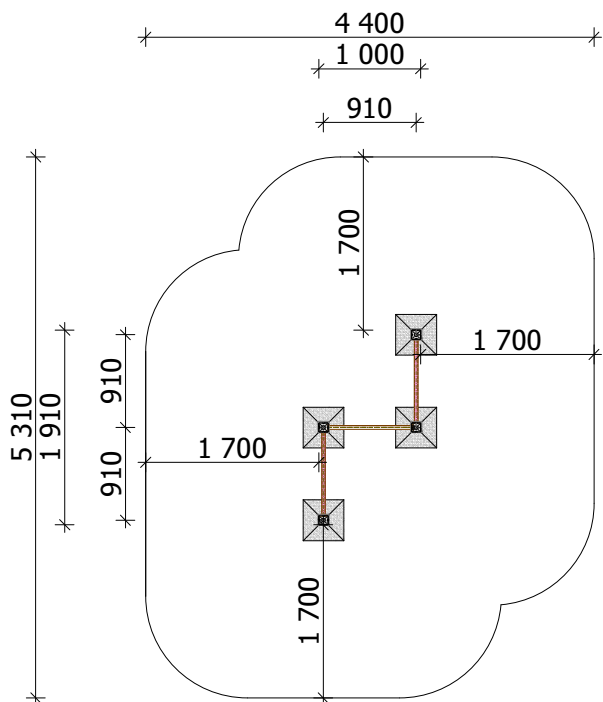
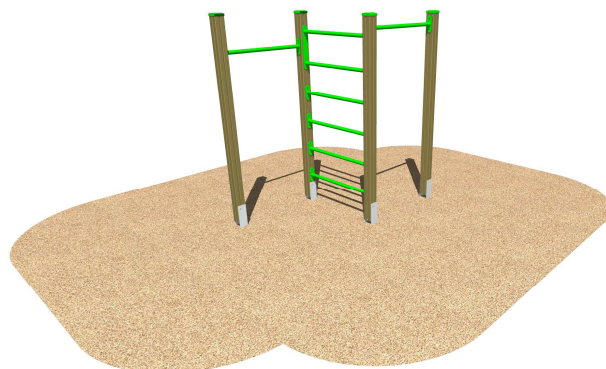

Equipment safety checkings must be performed once in a week in high vandalism risk areas.

Maintenance are required once in every 3 months, depending on usage

Minimal required area - 20 m²

Length: 1 000 mm
Width: 1 910 mm
Height: 1 900 mm

Playground are provided for outdoor use in supervising of adults

Length of safety area: 4 400 mm
Width of safety area: 5 310 mm
Required safety area: 20 m²

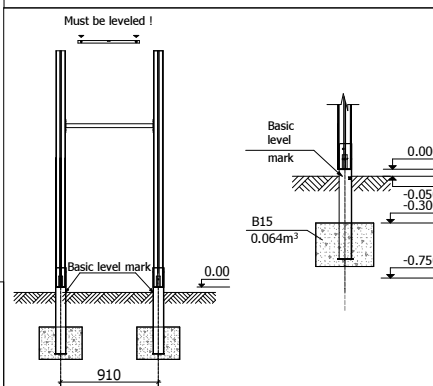

Play equipment are established with concreted steel foundation in equipment location. Equipment are suitable for use in two days after concreting, when the foundation are totally solid. During assembling there are not children allowed in area.

Adequate temperature

T_{min} -33.2 °C
T_{max} +64.1 °C

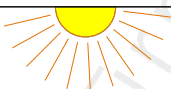

Snow load

Small



Wing load

Small

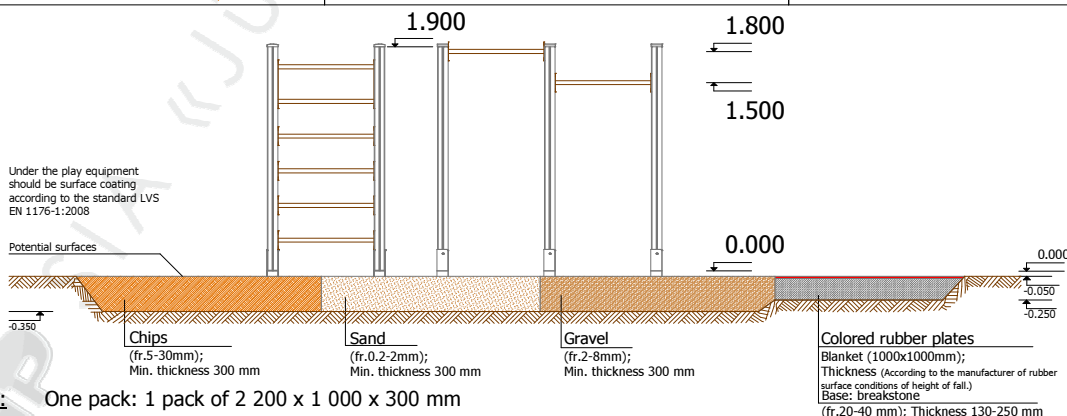

Transportation: One pack: 1 pack of 2 200 x 1 000 x 300 mm

Spare parts: All needed spare parts and elements, when warranty time expires can be ordered in „Jūrmalas Mežaparki” Ltd., and all the goods will be ready for delivery in 3 days.