

PRODUCT SHEET
 REV 2.0 - EN201902
YS900 AURIGA

CLIMBING



HANGING



WALK/BALANCE



CATALOG COLLECTION	DYNAMICS
DIMENSIONS (L x W x H) in cm	270 x 330 x 320
MAXIMUM CFH	150
IMPACT ATTENUATING SURFACE	min. 35,00 m ² - MAX 39,00 m ²
SUGGESTED AGE OF USE	10 - 12
COMPOSITION	<ul style="list-style-type: none"> - n°3 aluminium Ø127 round poles - n°1 aluminium deck - n°4 metal barriers - n°1 metal stepladder - n°1 metal tubular slide - n°1 metal arch climbing - n°3 HDPE sheet decorations

SECURITY AREA

570

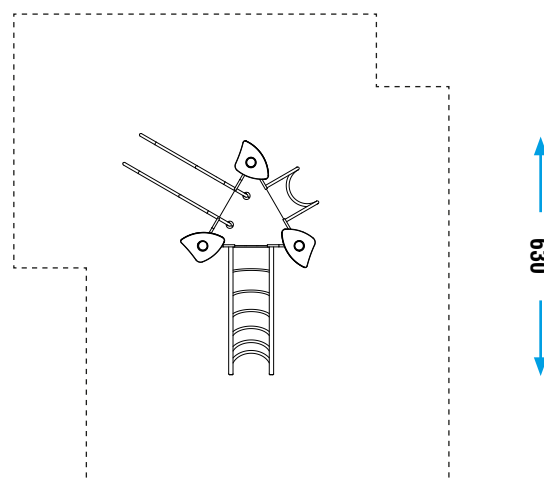

Make a proper security surface according to CFH. **Periodic maintenance is mandatory**, following manual supplied to customer.