



CLIMBING



HANGING



WALK/BALANCE



CATALOG COLLECTION	DYNAMICS
DIMENSIONS (L x W x H) in cm	290 x 310 x 330
MAXIMUM CFH	150
IMPACT ATTENUATING SURFACE	min. 31,75 m ² - MAX 36,00 m ²
SUGGESTED AGE OF USE	8 - 12

COMPOSITION

- n°3 pali portanti in alluminio tondi Ø127
- n°1 pedana in alluminio
- n°1 parapetto in metallo
- n°2 parapetti in lastra di HDPE
- n°1 scivolo modulare
- n°1 spalliera in metallo
- n°1 scaletta in metallo
- n°1 arrampicata in lastra di HDPE e metallo
- n°1 decoro in lastra di HDPE

SECURITY AREA

← 590 →

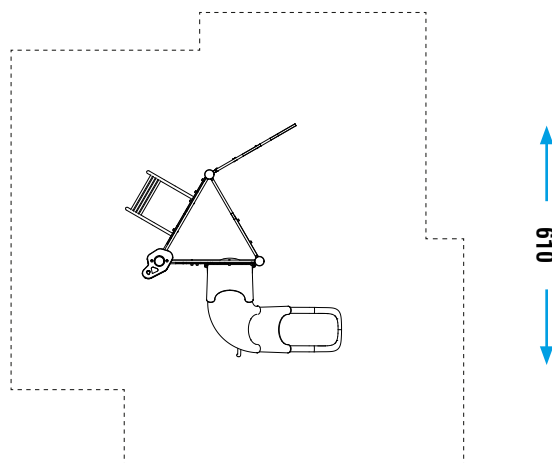

Make a proper security surface according to CFH. **Periodic maintenance is mandatory**, following manual supplied to customer.