

<b>CATALOG COLLECTION</b>	DYNAMICS
<b>DIMENSIONS (L x W x H) in cm</b>	520 x 400 x 330
<b>MAXIMUM CFH</b>	200
<b>IMPACT ATTENUATING SURFACE</b>	min. 44,25 m <sup>2</sup> - MAX 59,50 m <sup>2</sup>
<b>SUGGESTED AGE OF USE</b>	8 - 12

<b>COMPOSITION</b>	<ul style="list-style-type: none"> <li>- n°6 aluminium Ø127 round poles</li> <li>- n°2 aluminium decks</li> <li>- n°3 metal guardpanels</li> <li>- n°3 HDPE sheet guardpanels</li> <li>- n°1 modular slide</li> <li>- n°1 HDPE sheet climbing</li> <li>- n°1 metal ladder</li> <li>- n°1 monkey bars</li> <li>- n°1 metal arch climbing</li> <li>- n°1 spinner</li> <li>- n°2 HDPE sheet decorations</li> </ul>
--------------------	---

**SECURITY AREA**  
700

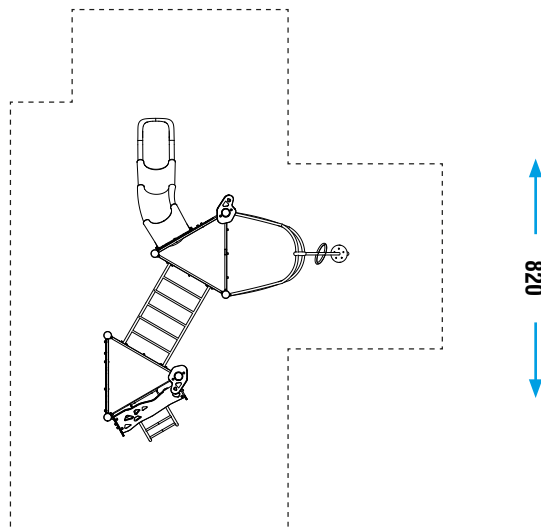

Make a proper security surface according to CFH. **Periodic maintenance is mandatory**, following manual supplied to customer.